



Model
Chrome steel



Model
Anthracite

Model Grey matt



Features

- Industrial washing machine for gentle fabric care
- «Expert» control with 20 standard programmes and 24 freely programmable positions
- Intuitive operation with 4.3" colour display
- High spin speed for minimum residual moisture (up to 46%)
- Stainless steel drum and washing liquor tank for efficient washing and rinsing processes
- Cold, hot or soft water connection (selectable on site)
- Language selection button for 23 languages
- Start delay with calendar function
- Swiss made and designed for over 30,000 operating hours

Options

- «Expert+» control with 20 standard and 90 profiClean programmes and 24 freely programmable positions
- WLAN interface for programme and software updates
- Connection for 8 liquid detergent dosing pumps
- Standard machine plinth (280 mm)
- Special machine plinth (355 mm)
- Machine plinth with fluff filter drawer
- Mains blocking set (load shedding/current peak)

	W130	W160
	130 l	160 l
1:9	14 kg	18 kg
1:10	13 kg	16 kg

Technical data proLine W130 / W160

Company or brand name		Schulthess	
Device type		Washing machine	
Type or sales description	proLine	W130	W160
Product no.		4204.1	4205.1

Properties

Filling factor (1:9)	kg	14	18
Filling factor (1:10)	kg	13	16
Drum volume	l	130	160
Drum opening	Ø mm	450	450
Drum diameter	mm	620	620
Drum depth	mm	427	527
Spin speed	rpm	1100	1100
g-factor		419	419
Residual moisture	%	48	48
Programme duration cold water connection (min.) ²⁾		55	55
Programme duration hot water connection 70 °C (min.) ²⁾		46	46
Energy consumption ^{3)/4)}	kWh	2,4 / 0,45	3,1 / 0,45
Water consumption ²⁾	l	112	144

Electrical installation

Supply voltage	V	400 3N~ / 50 Hz	400 3N~ / 50 Hz
Connected load	kW	14,9	18,0
Electric heating	kW	14,5	17,6
Drive	kW	1,5	1,5
Protection	AT	25	32

Sanitary installation

Water pressure on site	MPa	0,15 – 1,0	0,15 – 1,0
Cold water hard inflow ¾-inch	l/min	> 13	> 13
Hot water supply from central boiler max. 70 °C ¾-inch	l/min	> 13	> 13
Drain quantity drain valve Ø 75 mm	l/min	260	260

Control system

	Expert/Expert+	Expert/Expert+
Standard programmes	•/•	•/•
24 programmes, freely programmable	•/•	•/•
ProfiClean sets	-/•	-/•
Disinfection programmes	-/•	-/•
WetClean programmes	-/•	-/•

- 1 Main switch
- 2 Electrical connection
- 3 Water connection
- 4 Overflow / Venting
- 5 Connection for liquid detergent
- 6 Drain pipe

Explanations:

- not available • available ²⁾Cotton 60 °C without pre-wash ³⁾Cotton 60° prg, cold water ⁴⁾Cotton 60° prg, hot water 70°

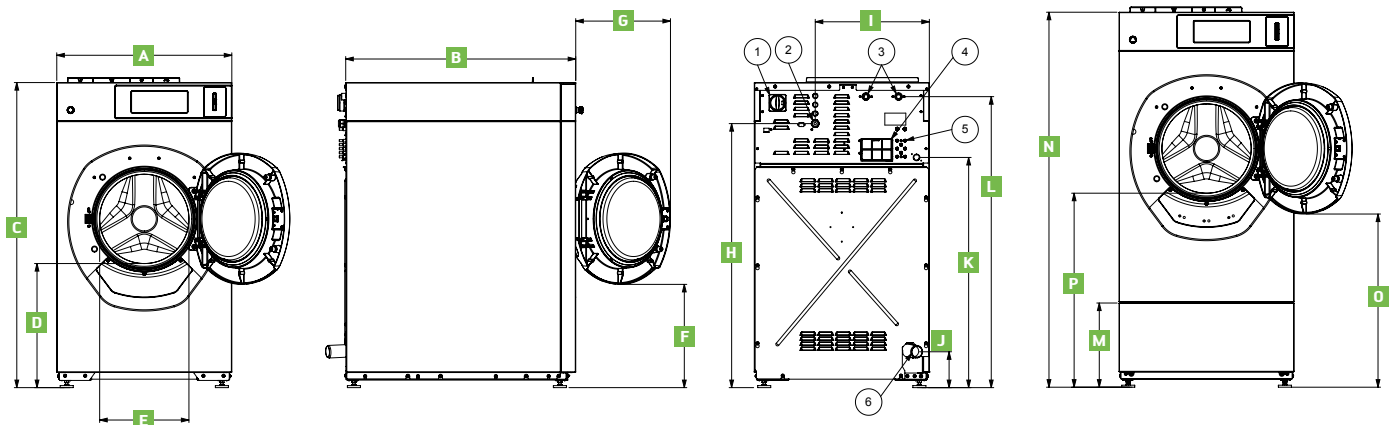

Dimensions

	A	B	C	D	E	F	G	H	I	J	K	L	M	N	O	P	Weight (kg)
W130	790	935	1360	530	450	450	-	1200	590	150	-	1300	330	1630	720	800	350
W160	790	1035	1360	530	450	450	-	1200	590	150	-	1300	330	1630	720	800	365