



Model
Chrome steel



Model
Anthracite

Model Grey matt



Features

- Professional washing machine with 8 kg load capacity (dry weight)
- Intuitive operation with 4.3" colour display
- 94 profiClean programmes and 24 freely programmable positions
- High spin speed (1600 rpm) for minimum residual moisture (c. 43%)
- Stainless steel drum and washing liquor tank for efficient washing and rinsing processes
- Cold and hot water connection for rapid programme time
- Large 3D washing drum with a volume of 70 litres
- Language selection button for 23 different languages
- Model with drain pump
- Start delay with calendar function
- Swiss made and designed for over 25,000 operating hours
- Door hinge right

Optionen

- Available in chrome steel (front and cover) or anthracite (complete housing)
- Model with direct drain (drain valve)
- Connection for up to 8 liquid detergent dosing pumps
- WLAN interface for programme and software updates
- RFID interface for card systems
- Standard machine plinth in all three colours (305 mm)
- Special machine plinth in all three colours (522 mm)
- Machine plinth with fluff filter drawer for mop module (401 mm, only for V Var.)
- Door hinge left

Technical data topLine 9240

Company or brand name	Schulthess		
Type of appliance	Washing machine		
Type or sales description	topLine 9240		
Product number	9240.2		
Application features			
Load capacity	max. kg	8	
Drum capacity	l	70	
Spinning speed	max. rpm	1600	
g factor	g	690	
Residual moisture ¹⁾	%	43	
Structural design			
Footed appliance with work surface	•		
Door hinge ²⁾	r/l/w		
Dimensions			
Height	cm	90	
Width	cm	63	
Depth including distance from wall	cm	72	
Depth with door open (front loader)	cm	116	
Height (adjustable)	cm	1	
Weight when empty	kg	102	
Equipment			
Tub	stainless steel		
Loading opening	Ø cm	34 / 180°	
Automatic door opening	•		
Connecting cable	m	1,6	
Drain			
- Drain hose with benda, only model (P)	m	1,5	
- Model with drain pump (P)	Ø mm	21	
- Model with drain valve (V)	Ø mm	50	
Electric power and water supply			
Electrical connection ³⁾			
Voltage / connected loads / fuse	400 V 3 N~ / 50Hz / 4,6kW / 10A 400 V 2 N~ / 50Hz / 4,6kW / 10A 230 V 1 N~ / 50Hz / 2,5kW / 13A 230 V 1 N~ / 50Hz / 2,3kW / 10A		
Water connection			
- Pressure hose G ¾" with fine filter	m	1,5	
- Can be connected to cold water / hot water	cold water / hot water 70 °C		
- Water pressure	bar	1-10	
Safety and service			
Conforms to the European Machinery Directive	2006/42/EC		
Country of origin	Switzerland		
Guarantee	1 year		
Service by	Hi-Seasons		
Name and address of supplier	Schulthess Maschinen AG, CH-6330 Cham ZG		

Explanations:

- Available or yes • Not available or no

1) Values determined in the 60°C cotton programme.

2) Door hinge: l = left, r = right, w = can be changed

Example: l/w means that the machine is delivered with the door hinge to the left, but the direction of opening can be changed.

3) Information on switchover options can be found in the installation instructions, where required.

Note: State of the table details as 05.2023, subject to further developments.

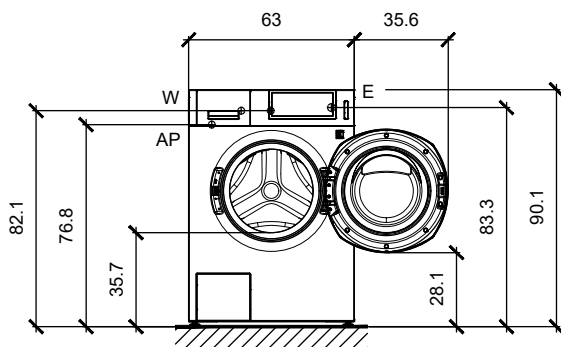

Version with pump

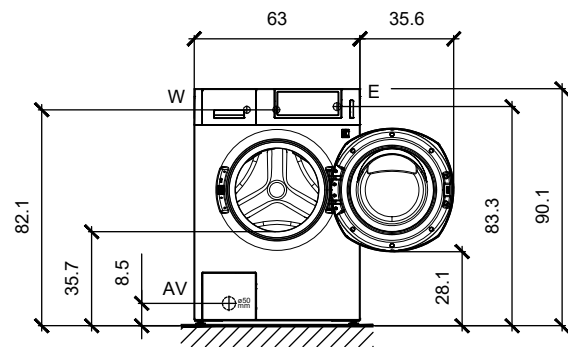

Version with drain valve